

Coupler Tec Capacitive Coupling Technology



COUPLER TEC™
ELECTRONIC RUSTPROOFING
ProTEction From Rust! GUARANTEED!



ProTEction From Rust! GUARANTEED!

Contents



2
Introduction
About Us

3
CouplerTec
How CouplerTec Works

7
Benefits
Product Benefits

8
Questions
Commonly Asked Questions

11
Automotive
Systems Range

19
Commercial
Heavy Duty
Range

www.couplertec.com



CouplerTec Electronic Rustproofing is a wholly owned and operated Australian company which is based at Burleigh Heads on Australia's Gold Coast.



CouplerTec is the World leader in the manufacture and supply of Electronic Rustproofing Systems for the Automotive and Heavy Equipment industries. More than 600,000 CouplerTec Electronic Rustproofing Systems have been sold worldwide. CouplerTec's Internationally Patented 'Capacitive Coupling Technology' has a superior reputation for product effectiveness, quality and reliability.



All CouplerTec products are designed, engineered, and manufactured in Australia to strict ISO 9001 Quality Standards and have been tested to CISPR 25 Electromagnetic Compatibility Standards. Approval number N28214.



CouplerTec's 'Capacitive Coupling Technology' has been awarded the following International Patents; Patent approved Australia 2007236536, Patent approved USA 12/295,271, Patent approved Canada 2642716, Patent pending UAE 1021/2008 and Patent pending Europe 07718629.

CouplerTec Mission Statement

The company's mission is:
To provide vehicle owners throughout the world with a proven, environmentally friendly, cost effective method of protection against rust & corrosion.

How CouplerTec Works

What Can Be Protected?

CouplerTec's Patented 'Capacitive Coupling Technology' is an Electronic corrosion control process that can be used on any mobile or fixed above ground (non-submerged) application such as; motor vehicles (cars, trucks buses), heavy machinery/equipment (tractors, forklifts, graders, loaders, dozers, excavators and cranes etc), towers, generators and sheds. Almost any above ground metal structure can be protected using CouplerTec's Patented Capacitive Coupling Technology.

The CouplerTec Difference!

CouplerTec's Patented Capacitive Coupling Technology is demonstrably different from the more traditional forms of electronic corrosion control because it was specifically designed from the outset to operate in an open air environment, unlike Impressed Current Cathodic Protection (ICCP) which requires a relatively abundant conductive medium (moist soil or water) completely surrounding the metal object being protected.

What Is Rust?

Rust is the normal electrochemical process of metals returning to their natural unrefined state. It occurs when Iron, Oxygen and Water (air moisture) combine. The rusting process can be accelerated when Iron is subjected to nature's minerals, chemicals and temperature fluctuations.



Why Does Rust Happen?

Iron and oxygen have opposite charges so they seek out each other to combine. When they combine, the iron loses electrons to oxygen atoms. This is called oxidation and when it happens it produces a chemical reaction forming Fe_2O_3 Iron Oxide otherwise known as Ferric Oxide, or more commonly known as rust.

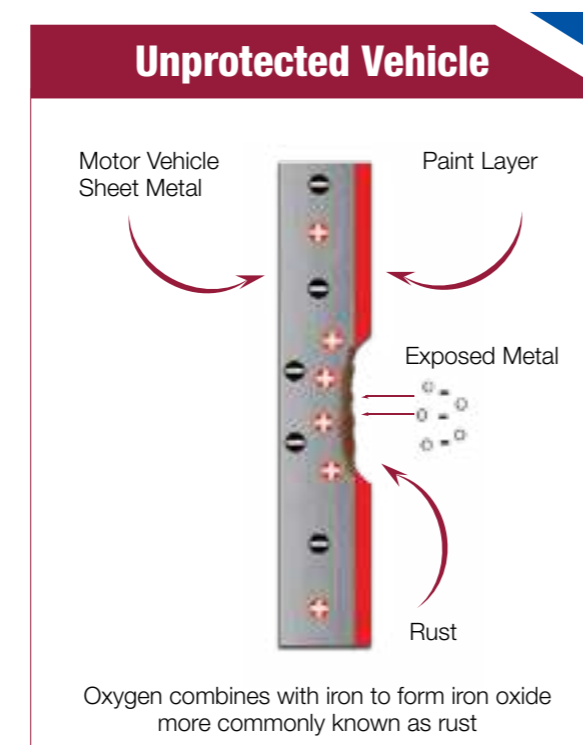
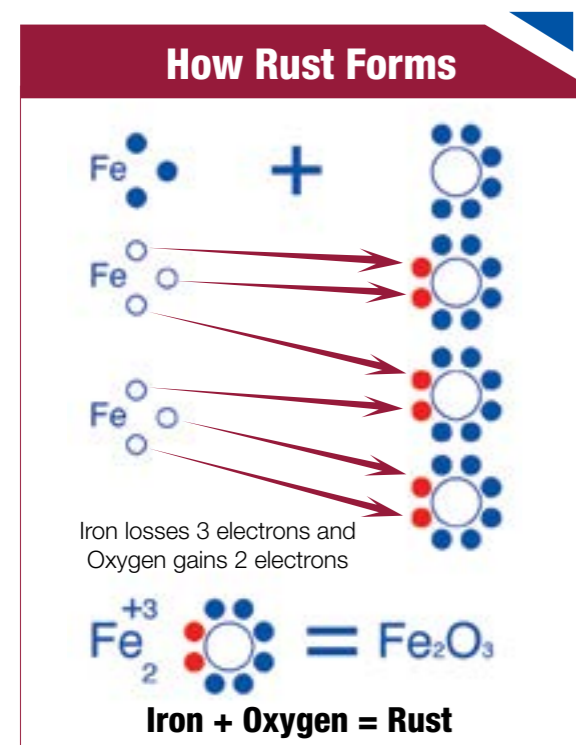

How CouplerTec Works

How CouplerTec's Capacitive Coupling Technology Works!

CouplerTec's Patented Capacitive Coupling Technology interferes with the electrical charge between Iron and Oxygen so it becomes hard for these elements to combine to form rust. In other words, the technology interferes with the metal's ability to react with Oxygen.

CouplerTec's Capacitive Coupling Technology achieves this by creating a negative (-) electrostatic surface charge on the metal surface of the protected structure. The (-) Oxygen atom is repelled by the (-) electrostatic surface charge.

This (-) electrostatic surface charge is created by building a Capacitor within the protected structure. A capacitor is an electrical component used to store a charge, consisting of two conducting surfaces separated by a nonconductive dielectric. The CouplerTec system consists of two components that we use to build our Capacitor within the protected structure.



CouplerTec™ Electronic Module

The first component is our CouplerTec Electronic Module which is connected to a 12V power source, either a 12V Battery or 12V power pack plugged into mains power (mainly used for static structures).

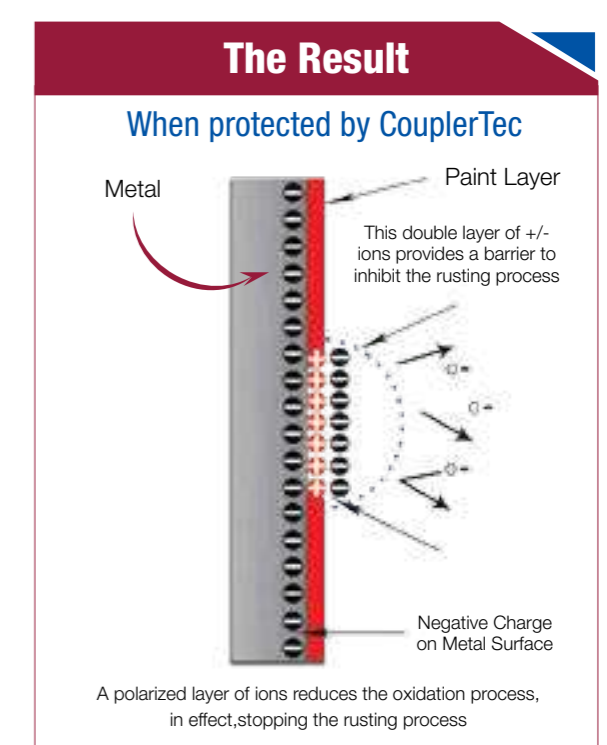
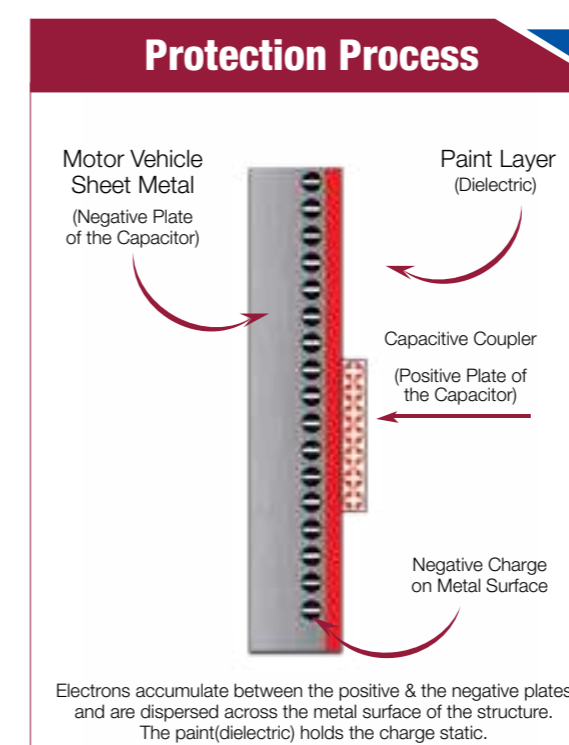

How CouplerTec Works

The module draws a very small charge from the power source and transforms this into an output voltage of 400V (Peak) and from 200V (RMS typical), strong enough to easily be read on a volt/multi-meter.

The CouplerTec module generates frequency signals in the 200KHz range. The voltage and frequency created by the module is then transferred to the second component, which is our Capacitive Coupler.

The Capacitive Coupler is a conductive plate which is affixed directly onto the painted surface of the structure using a high bond adhesive.

The Capacitive Coupler, when charged by the voltage now acts as the positive plate' of the Capacitor that we are building.

The frequency applied to the Capacitive Coupler combined with Capacitance induces the electrostatic charge to the metal surface of the structure.

This then makes the structure act as the negative plate of the Capacitor.

Electrons are accumulated between the Positive and Negative plates of the Capacitor.

The frequency which induced the charge also disperses these electrons across the surface of the structure.

The structures paint work becomes the 'dielectric' which in turn will hold the electrons on the metal surface and stop them from flowing away.

Should a protected structure's paintwork become compromised (e.g. stone chip or scratch) resulting in exposed bare metal, then over time a very thin layer of surface rust may eventually form on the bare metal surface.

This layer of surface rust takes the place of the paint work and becomes the dielectric, which in turn holds the charge static. The surface rust will turn a dark brown colour, this is non-active ferric oxide and will not progress any further.

Internationally Patented Technology

All CouplerTec™ Electronic Rustproofing systems are fully digitally controlled using state of the art microprocessor technology, similar to that found in current mobile phones. The microprocessor is programmed with a process called **'monitored and controlled performance'**. This is where the microprocessor monitors and controls the activity between each internal circuit and their own dedicated Capacitive Coupler. This ensures that the required level of energy, frequency and capacitance is applied constantly via the capacitive coupler to induce the electrons throughout the body of the vehicle/structure.

The CouplerTec system confirms that it is working correctly by way of a Green flashing L.E.D (light emitting diode). Conversely, the system will also indicate the detection of a fault by way of a Red flashing L.E.D. In the event of a fault, the system will automatically reset after the fault has been rectified.

The electronics are Solid State (which means there are no moving parts) and the electronic board is encapsulated in an epoxy resin which makes it air tight and water tight. Therefore, these systems will enjoy an indefinite life span.



Additional Product Benefits

Greater Vehicle Re-Sale Value

Use of a CouplerTec System will help retain a greater vehicle re-sale value!



Reduce Costs

CouplerTec Systems help reduce maintenance costs associated with rust and corrosion!



Easily Transferable

CouplerTec Systems are easily transferred from one vehicle to another!



Easy to Install

CouplerTec Systems are simple and easy to install!



Prevents Rust Damage

CouplerTec Systems prevents rust damage on stone chips and scratches!



Eliminates Static Electricity

CouplerTec Systems eliminate static electricity



Stops Paints from Oxidising

CouplerTec Systems keep paintwork looking like new for longer. Stops paint from oxidising!



Protects Vehicle Inside & Out

CouplerTec Systems protect the entire vehicle, inside & out!



Commonly Asked Questions

Q Why rust proof a vehicle?

A The majority of motor vehicles are made from metal and unfortunately when metal is combined with air and moisture the result is RUST. Simply washing a vehicle increases the chances of RUST damage. Any type of moisture, humidity, minerals, chemicals, and airborne salt as an example can also assist in the forming of RUST. CouplerTec Electronic Rust Proofing Systems prevents rust from taking hold.

Q What is the difference between CouplerTec and the conventional spray-on rust proofing methods?

A Sprays and coatings are only as good as where they can reach. Unless the vehicle is completely stripped and then a spray coating applied, it is not possible to protect any more than 50% of the vehicle's surface. CouplerTec protects 100% of the vehicle's surface including all the hidden and hard to reach areas and it also prevents rust damage caused by stone chips and scratches which spray coating's can not protect against.

Q Will a CouplerTec Electronic Rust Proofing System work WITH conventional rust proofing sprays?

A Absolutely YES! The addition of a CouplerTec system will improve and enhance any sprays already applied to your vehicle; however, the addition of sprays is not necessary.

Q Are all Electronic Rust proofing Systems the same?

A NO – Electronic rustproofing has been around for decades in the forms of Impressed Current Cathodic Protection (ICCP) & Sacrificial Anodes, which were designed for protecting inground pipe lines and boats etc from rust. These devices in their true form are effective for their intended use; however, they scientifically cannot work on motor vehicles. CouplerTec's Patented Capacitive Coupling Technology has been specifically developed for protecting motor vehicles from rust. CouplerTec is acknowledged as the world's leader in the design and manufacture of electronic rust proofing

systems for the automotive and heavy machinery industries.

Q My car already has some rust - will CouplerTec help?

A Yes - Even in severe cases, CouplerTec systems have been proven to slow the corrosion process. It is recommended that a CouplerTec system be installed prior to having your vehicle's rust repaired, this will allow time for the CouplerTec Technology to stabilise any existing corrosion. But remember, as good as this product is, it is not a miracle cure for badly rusted vehicles, as the more rust the vehicle has, the harder it is to stop.

Q Has the CouplerTec technology been tested?

A Yes. CouplerTec systems have passed many extensive field test evaluations which have been carried out within some of the most corrosive environments on the face of the planet. In addition, CouplerTec's unique, patented technology has been approved by ACMA (Automotive Chamber of Professionals) Independent testing has been carried out by Bosch. CouplerTec systems comply with CTICK approval N28214 and have also been tested to EMC standard CISPR25. There are multiple international patents and CouplerTec is acknowledged internationally and respected as the global leader and authority in electronic rust proofing.

Q How do I know if the CouplerTec Electronic Rust proofing System is operating correctly?

A The CouplerTec system confirms correct operation by way of a green flashing light.

Q Will the CouplerTec system work on vehicles with aluminium panels?

A Yes it will. The CouplerTec system works with aluminium in exactly the same manner as it works with steel. It will prevent the aluminium from oxidization.

Commonly Asked Questions

Q Will a CouplerTec system flatten my battery?

A No - CouplerTec systems draw less power from the battery than is required to power a dash board clock.

Q Will the addition of a CouplerTec system to my vehicle void the manufacturer's new vehicle warranty? And will it interfere with on board computers?

A No - CouplerTec complies with the strict testing standards for Electromagnetic Compatibility (EMC) and will not interfere or hurt anything, and there is no reason why a CouplerTec system could ever void a manufacturer's warranty.

Q Are there different CouplerTec systems for different size vehicles?

A Yes - It is impossible to have one model that suits all size vehicles and the specific unique individual driving conditions, environs and exposure to corrosive conditions. Each CouplerTec system type differs in the number of internal circuits and capacitive couplers that may be required.

Q If I sell my vehicle can I take the CouplerTec system off and transfer it to another vehicle?

A Yes - The CouplerTec system is easily transferred from one vehicle to another.

Q Are there any other benefits of fitting a CouplerTec system to my vehicle?

A Our research has determined that the addition of a CouplerTec system to a vehicle will ensure that small paint chips and scratches will not spread. There is also anecdotal evidence to suggest that the technology ensures the vehicle's paintwork and lustre is kept looking like new for longer.

Q How many anodes does CouplerTec have?

A None - CouplerTec's patented Capacitive Coupling Technology uses capacitive couplers, which are affixed to the vehicles painted surface and are not sacrificial like anodes are. Any product that uses anodes or runs a wire straight to a screw or bare metal is using Cathodic/ Impressed current technology that was designed for boats or underground pipes etc - NOT motor vehicles.

Q Is CouplerTec the more expensive option, over other rust proofing methods?

A No - Unlike conventional sprays and coatings that need to be reapplied on a regular basis. A CouplerTec system is a once only cost and the module can be easily transferred to another vehicle.

Q How long will a CouplerTec system last?

A The system's life is indefinite, the electronics are solid state (no moving parts) and the electronic board is totally encapsulated in an epoxy resin that makes it completely sealed.

Q Can you add extra Capacitive Couplers to an existing system to make it bigger?

A NO, every Capacitive Coupler must operate off it's own dedicated circuit in order for this technology to work.

Q Are there any similar products to CouplerTec?

A No, CouplerTec's Capacitive Coupling Technology is patented, therefore, if another product existed that was similar to CouplerTec then it would be in breach of the CouplerTec patents. CouplerTec is the ONLY proven form of Electronic Rustproofing to protect motor vehicles and heavy machinery.

CouplerTec Premium Users

CouplerTec Electronic Rustproofing Systems are protecting vehicles and machinery from rust & corrosion throughout Australia and throughout the world!

More than 600,000 systems have been sold worldwide.

CouplerTec is used and recommended by;



Mining Companies

CouplerTec's Capacitive Coupling Technology has proven to be the only truly effective Electronic Rust proofing system to be trusted and used in the mining industry to control corrosion. Vehicles and machinery working within the mining industry are exposed to some of the most corrosive environments on Earth.

CouplerTec Electronic Rustproofing Systems are currently being used as the preferred rust proofing method in various mines around the World; this includes gold, silver, copper, salt, coal and mineral mines.



Surf Life Saving Clubs

Surf Life Saving Club vehicles are consistently subjected to the damaging effects of Salt Water and Seaspray. CouplerTec is used and recommended throughout the Australian Surf Life Saving Club fraternity.



Government Authorities

CouplerTec Electronic Rustproofing is the preferred method of rust proofing used by many Local, State and Federal Authorities throughout Australia.

Automotive Range



Automotive Systems Range

The Automotive Range of CouplerTec™ Electronic Rustproofing Systems consists of five individual Models that cater for all types of Motor Cars (hatchbacks, sedans and wagons), Vans, Four Wheel Drives (4WD) and SUV's. It's simply not possible to have one size system that suits every vehicle, because vehicles come in different sizes and condition (some already have pre-existing rust), and are exposed to diverse environmental influences for differing periods of time.

Please note that if a vehicle has existing minor rust problems then we recommend the use of a larger system than what would normally be recommended. E.g. A 4WD that is in good condition (no existing rust) that is Frequently exposed to a highly corrosive environment would normally be fitted with a 4WD Heavy Duty System, however, if a 4WD had minor rust problems and was Frequently exposed to a highly corrosive environment then it should be fitted with a larger 4WD Extreme Heavy Duty System.

© 2012 CouplerTec Electronic Rustproofing. All rights reserved. CouplerTec™, ® and the CouplerTec logo are trademarks of CouplerTec Electronic Rustproofing. Because of our ongoing commitment to product quality and innovation, CouplerTec reserves the right at any time to discontinue or change specifications, design, features or models without incurring any obligation.



“ From the city driver to the most serious off road adventurer, there is a **CouplerTec** system to suit every car, 4WD or SUV owners requirements! ”

Protection for Motor Cars



Model: 2WD Heavy Duty System
Product Code: 2WDHDSFK
Description: CouplerTec Electronic Rustproofing System 12V
 - Two Capacitive Couplers

This system has been specifically designed to protect motor cars (hatchbacks, sedans, wagons and small vans*) from rust. It will also dramatically reduce the effects of corrosion on those vehicles which are frequently exposed to use within highly corrosive environments such as; driving on salted roads. In other words, it will extend the life of these vehicles. As good as this product is, it is not a miracle cure for badly rusted vehicles, as the more rust or corrosion a vehicle has, the harder it is to stop. (*For large Vans LWB use the larger 4WD Heavy Duty System).



CouplerTec SYSTEM
 (Located near Main Battery)

* New car installation only

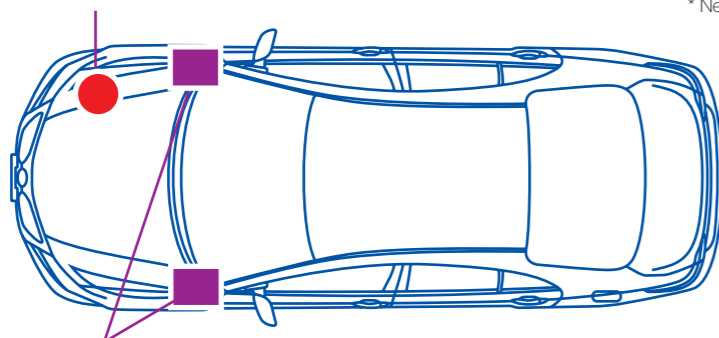

COUPLERS - FRONT
 (Located on: Fire wall/Inner guard)

Protection for 4WD's/SUV's



Model: 4WD System
Product Code: 4WDSFK
Description: CouplerTec Electronic Rustproofing System 12V
 -Two Capacitive Couplers

The 4WD System has been specifically designed to protect the Four Wheel Drive or SUV vehicle from rust, even when these vehicles are exposed to *OCCASIONAL use within highly corrosive environments such as; driving on salted roads or beaches. (*1 day per month, alternatively, up to two weeks per year). This product is best suited to vehicles that are in reasonably good condition e.g. NO existing rust. (For older vehicles or vehicles with minor rust problems, use the larger 4WD Heavy Duty System or 4WD Extreme Heavy Duty System).



CouplerTec SYSTEM
 (Located near Main Battery)

COUPLER - REAR
 (Located on Inner guard within the Jack housing/Tail-light area)

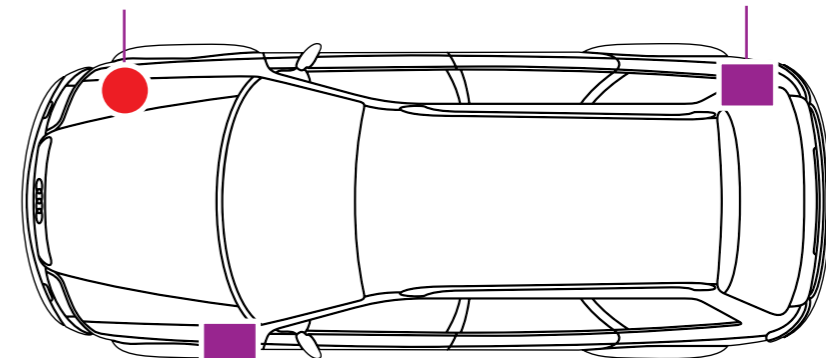

COUPLER - FRONT(Located on: Fire wall/Inner guard)

Protection for 4WD's/SUV's



Model: 4WD Heavy Duty System

Product Code: 4WDHDSFK

Description: CouplerTec Electronic Rustproofing System 12V - Four Capacitive Couplers

The 4WD Heavy Duty system has been specifically designed to protect the Four Wheel Drive or SUV vehicle from rust, even when these vehicles are exposed to ***FREQUENT** use within highly corrosive environments such as; driving on salted roads or beaches. This system may also benefit older 4WD vehicles that are suffering from minor existing rust problems. But remember, as good as this product is, it is not a miracle cure for badly rusted vehicles, as the more rust a vehicle has, the harder it is to stop. (*Weekend use)

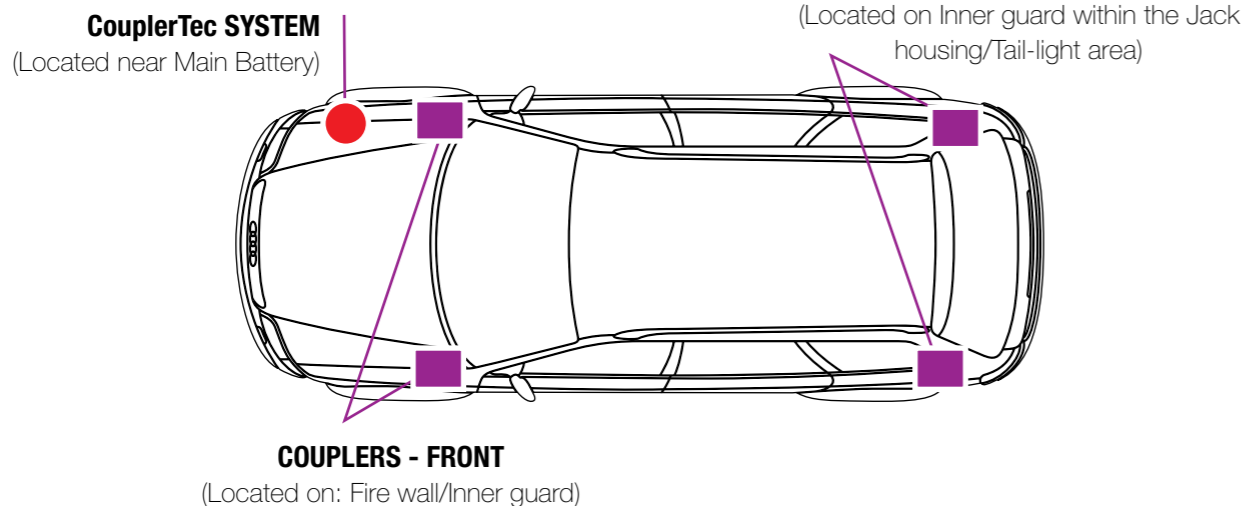

Protection for 4WD's/SUV's



Model: 4WD Extreme Heavy Duty System

Product Code: 4WDXHDSFK

Description: CouplerTec Electronic Rustproofing System 12V - Six Capacitive Couplers

The 4WD Extreme Heavy Duty System offers the ultimate in protection. Specifically designed to protect Four Wheel Drive vehicles used by Surf Life Saving Clubs and Professional Fisherman, it will dramatically reduce corrosion on Four Wheel Drive vehicles which are exposed to ***CONSTANT** use within highly corrosive environments such as; driving on salted roads or beaches. This system may also benefit older 4WD vehicles that are suffering from minor existing rust problems. But remember, as good as this product is, it is not a miracle cure for badly rusted vehicles, as the more rust a vehicle has, the harder it is to stop. (*Daily use)

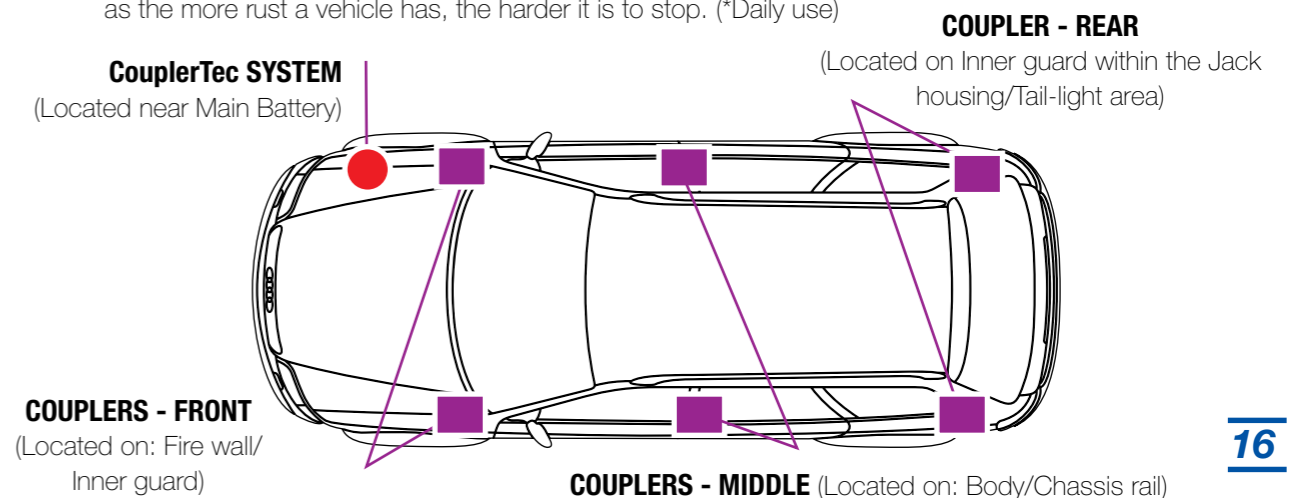

Protection for 4WD's/SUV's



Model: 4WD Mine Specification System

Product Code: 6MSSFK

Description: CouplerTec Electronic Rustproofing System 12V - Six Capacitive Couplers

The Mine Specification System has been especially designed to offer protection against rust on Four Wheel Drive light mining vehicles. This system will work on those vehicles fitted with battery Isolation Switches, thus offering protection to the vehicle whilst the vehicle is shut down. This system when fitted correctly will dramatically reduce the effects of rust on mining vehicles which are subjected to highly corrosive environments on a full-time basis. The system also comes complete with Protective Covers that ensure that the Capacitive Couplers are not damaged by high pressure cleaning equipment used on mine sites.

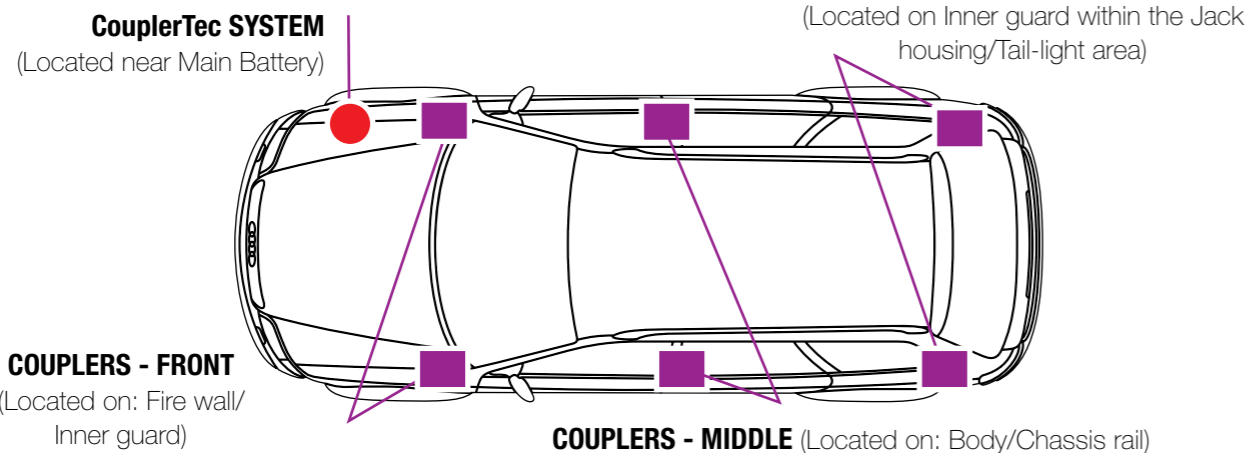

Spare Parts – Automotive Systems Range

Fitting Packs come with all the necessary components & fitting instructions required to transfer your CouplerTec System from one vehicle to another.



Product Code: 2CFP

Description: 2 Capacitive Coupler Fitting Pack, suits models; 2WD Heavy Duty System & 4WD System.



Product Code: 4CFP

Description: 4 Capacitive Coupler Fitting Pack, suits model; 4WD Heavy Duty System.



Product Code: 6CFP

Description: 6 Capacitive Coupler Fitting Pack, suits models; 4WD Extreme Heavy Duty System & Mine Specification System.



Product Code: 1COUP

Description: Capacitive Coupler (suits systems within the Automotive Systems Range) Size 80mm x 50mm



Product Code: 1PC

Description: Protective Capacitive Coupler Cover, suits 1COUP

Commercial Heavy Duty Range



Commercial Heavy Duty Range

These larger CouplerTec™ Commercial Heavy Duty Systems have been specifically designed to provide rust protection for large trucks, buses and heavy machinery. No matter how large the truck, bus or machine, or how corrosive the environment in which it operates, there is a suitable sized system to suit every application. There are five models in this range, ranging in size from Four to Twelve Capacitive Couplers. All systems can operate off either 12V or 24V input.



Pictured Top: The larger 12COMM Commercial Heavy Duty Module and the smaller Mine Specification Module from the Automotive-range.

Pictured Right: The larger Commercial Capacitive Coupler and the smaller Automotive Capacitive Coupler.



© 2012 CouplerTec Electronic Rustproofing. All rights reserved. CouplerTec™, ® and the CouplerTec logo are trademarks of CouplerTec Electronic Rustproofing. Because of our ongoing commitment to product quality and innovation, CouplerTec reserves the right at any time to discontinue or change specifications, design, features or models without incurring any obligation.



Commercial Heavy Duty Systems Range

4COMM



Model: 4COMM
Product Code: 4COMMSFK
Description: CouplerTec Commercial Electronic Rustproofing System 12/24V
 - Four Capacitive Couplers.

This 4COMM system offers protection for Heavy Vehicles and Machinery that are up to 6m in length, also suitable for smaller sized Heavy Vehicles or Machinery up to 4m in length that will be used in highly corrosive environments.

IMPORTANT INFORMATION: Vehicle/Machine dimensions should not exceed the following dimensions: 3 metres in Width, 4.5 metres in Height and the Length specified herein.



Commercial Heavy Duty Systems Range

6COMM



Model: 6COMM
Product Code: 6COMMSFK
Description: CouplerTec Commercial Electronic Rustproofing System 12/24V
 - Six Capacitive Couplers.

This 6COMM system offers protection for Heavy Vehicles and Machinery that are up to 8m in length, also suitable for smaller sized Heavy Vehicles or Machinery up to 6m in length that will be used in highly corrosive environments.

IMPORTANT INFORMATION: Vehicle/Machine dimensions should not exceed the following dimensions: 3 metres in Width, 4.5 metres in Height and the Length specified herein.



Commercial Heavy Duty Systems Range



8COMM



Model: 8COMM
Product Code: 8COMMSFK
Description: CouplerTec Commercial Electronic Rustproofing System 12/24V
 - Eight Capacitive Couplers.

This 8COMM system offers protection for Heavy Vehicles and Machinery that are up to 10m in length, also suitable for smaller sized Heavy Vehicles or Machinery up to 8m in length that will be used in highly corrosive environments.

IMPORTANT INFORMATION: Vehicle/Machine dimensions should not exceed the following dimensions: 3 metres in Width, 4.5 metres in Height and the Length specified herein.

Commercial Heavy Duty Systems Range

10COMM



Model: 10COMM
Product Code: 10COMMSFK
Description: CouplerTec Commercial Electronic Rustproofing System 12/24V
 - Ten Capacitive Couplers.

This 10COMM system offers protection for Heavy Vehicles and Machinery that are up to 12m in length, also suitable for smaller sized Heavy Vehicles or Machinery up to 10m in length that will be used in highly corrosive environments.

IMPORTANT INFORMATION: Vehicle/Machine dimensions should not exceed the following dimensions: 3 metres in Width, 4.5 metres in Height and the Length specified herein.



Commercial Heavy Duty Systems Range



Model: 12COMM
Product Code: 12COMMSFK
Description: CouplerTec Commercial Electronic Rustproofing System 12/24V
 - Twelve Capacitive Couplers.

This 12COMM system offers protection for Heavy Vehicles and Machinery that are up to 14m in length, also suitable for smaller sized Heavy Vehicles or Machinery up to 12m in length that will be used in highly corrosive environments.

IMPORTANT INFORMATION: Vehicle/Machine dimensions should not exceed the following dimensions: 3 metres in Width, 4.5 metres in Height and the Length specified herein.



Spare Parts – Commercial Heavy Duty Systems Range



Product Code: 2COUP
Description: Capacitive Coupler (suits systems within the Commercial Heavy Duty Range)
 Size 116mm x 58mm



Product Code: 2PC
Description: Protective Capacitive Coupler Cover, suits 2COUP



FREECALL Within Australia

1800 NO RUST

1800 667 878

Phone

(07) 55220 200

International +61 7 55 220 200

Address

HQ International

1/5 Calabro Way, Burleigh Heads,
Gold Coast, QLD 4220,
Queensland, Australia

Postal Address

PO Box 2177, Burleigh Heads
Gold Coast, QLD 4220

Email

norust@couplertec.com.au



www.facebook.com/CouplerTec.rustproofing

© 2012 CouplerTec Electronic Rustproofing. All rights reserved. CouplerTec™, ® and the CouplerTec logo are trademarks of CouplerTec Electronic Rustproofing. Because of our ongoing commitment to product quality and innovation, CouplerTec reserves the right at any time to discontinue or change specifications, design, features or models without incurring any obligation.

www.couplertec.com